

## Manufacturability through Integrated and Design Innovation Continuum

Molu O. Olumolade

Central Michigan University Mt. Pleasant, MI. 48859

---

**ABSTRACT :** *There have been dramatic changes in the field of Computer Aided Manufacturing (CAM) in recent years, and despite the many advancements and changes, there is always a dire requirement for more cost-effective and efficient workholding methods and devices. This basic requirement of holding the workpiece has remained constant. Just as no single machine tool will perform every required operation, no individual jig or fixture can possibly hold every part. CoDeFi is a Concurrent Design of Fixture and part that enhances the manufacturability of the part and hence improves productivity. The idea is to transform a 3-D part design into a 2-D design model that can be accommodated on less sophisticated machinery such as a 3-axis CNC machining center or conventional machining methods. A computer simulation of the method when compared to using a multi-axis CNC machining center has resulted into time saving and code reduction.*

---

Date Of Submission: 15-08-2019

Date Of Acceptance: 29-08-2019

---

### I. INTRODUCTION

Product development is getting more complex and needs to innovate continuously. On the other hand common direction towards cost savings and shortening of design cycle forces to make the product design process highly efficient at high level of performance Hu and Aziz (2014). In addition, “When design research builds on design practice, it can contribute to both the theory and practice of design in ways richer than research that treats design as a topic. The crux of practice-based design research is that, where classical research is interested in singling out a particular aspect and exploring it in depth, design practice is characterized by balancing numerous concerns in a heterogeneous and occasionally paradoxical product” Koskinen, and Krogh (2014).

Engineers are intrigued by complexity. Industries, however, need to adopt the slogan “we make it simple. “The best way to achieve this is by setting quantifiable design goals at the beginning of development. Mathieu et.al. (2006) It is very important for any designer to showcase his/her design ability in order to reduce the complexity associated with some design structures that may hinder manufacturability

Yoori (2015) cited that “indeed, the field of design (and all of its associated professions, architecture, industrial design, integration design, engineering design, etc.) have increasingly become a major focal point for corporate social responsibility, which is not surprising since poorly designed products can greatly contribute to environmental and social degradation.”

Design for manufacture methodologies are used to improve a product’s manufacturability. Rajit Ranjan et.al. (2017) in combining integration of design for manufacturing methods with topology optimization in additive manufacturing explained that Design for manufacturability (DFM) implies that designer should ensure that their designs are easy to manufacture and minimize overall cost including assembly and logistics. DFM must ignore design for assemblability, which reducing number of parts and making the assembly easier and faster by simplifying the design of a product.

DFM is the art of developing high-quality products for the lowest possible manufacturing cost; it is mostly controlled by three factors:

- Feasible fabrication of the specified design
- Manufacturing time requirement
- Cost of operation.

DFM has emerged as guidelines to help a product development team to design a product that is easy to manufacture while other DFM approaches evaluate the manufacturability of a given product design with specific manufacturing process. In general, manufacturability evaluation approaches are to give the product design team a feedback on what aspects of the design make it infeasible or difficult to manufacture so that modifications can be made accordingly. The idea is to compare a product’s manufacturing requirements to existing manufacturing capabilities and measure the processing time and cost. These approaches can be used during conceptual design and detailed design steps.

DFM ultimately transforms into design for producability (DFP) which determines if a manufacturing system has sufficient capability to achieve the desired throughput and methods that estimates the throughput time. DFM and DFP are both related to the product manufacturability. In interactive design of 3D Geometry by Naoya et.al (2013) based on the limitation of certain materials such as wooden boards, sheet metals and paper presented a CAD system for designing an object that can be reconstructed from sheet material with parallel slits without tearing and gluing.

Engineers are trained to design for functionality and hence, their CAD tools predominantly design for this functionality. In order to satisfy some objectives of DFM and DFP, designing parts require just more than the functionality of the part. A good product development comes from designing for everything. Clive Dym and Patrick Little (2009). This considers all goals and constraints very early in the design. The worlds' demand for manufactured goods is growing at a staggering rate, and industry is responding to this demand with many new and sometimes radical ways of producing products. To ensure effective and efficient manufacturability of a part, design should always be done using the principle of concurrent engineering (CE), as this will have impact on cost.

There must be design guidelines to help the product design team create a better product design, and these design guidelines may be established for specific manufacturing processes. In addition, CE enables the integrated development of products and process with the goal of completing the entire cycles in a shorter time at lower overall cost and with fewer engineering design changes Venkataramana, Basavaraj, and Nagaraj (2013), Wentao Fu & Matthew I. Campbell (2015). To further enhance manufacturability, shape modification could be based on Gesture input that was classified into three types of forming a shape of special objects, expressing situation of operator and representing an action of shape modification, and adopting a rotation of parallel transfer of models in future extension Kazuga et.al (2013)

When designing parts or products, the first objective is the manufacturability and assembleability of such part. Sometimes, a design is produced based on functionality. It is evident that though functionality is important but a part is not complete if it is functional but not easily producible. Jigs and fixtures may sometimes enhance producability. The design for assembleability (DFA) part of this objective is what Gerald Hock referred to as "Good news, Bad News" situation. He explained further, "The good news is that we can identify improvements that make a design more competitive. The bad news is that when we identify improvements on an existing design, we can't always make the changes because of tooling costs, scheduling interruptions, etc." This is the motivation for this DFM approach. Mieke and Mascha (2014) explored the relationship between varying the use situation and usability and how designers deal or could deal with this relationship in their design process.

Maaik Kleinsmann, et al. (2017) presented four studies that together capture the value of design thinking in different early-stage innovation practices. Study 1 comprised a literature review on design thinking to form the basis of an agreed domain of discourse for design thinking in innovation. In Study 2, this shared domain of discourse was validated. This shared domain of discourse provided the input for Study 3, which investigated how innovators apply design thinking in early-stage innovation practices. It shows that the application of design thinking is dependent on the innovator's aim for the project, his or her vision on innovation, and the main challenge s/he is facing. This combination of characteristics is termed an image of design thinking. The images frame the application design activities in the context of the specific innovation project. Study 4 successfully validated the four images and shows that the combination of the images and the agreed domain of discourse can serve as a common language and a tool that allow capturing the value of design thinking in early-stage innovation.

Ilpo Koskinen<sup>1</sup> and Peter Gall Krogh (2015) examined three arguments dealing with theory, methods, and art. They argued that, early attempts at giving design a theoretical base usually failed. A better alternative, they argued, is to put practice first and give theory a role in explicating practice, as is done in the humanities and interpretive social sciences. As critical designers have pointed out, if design is seen as art, it may lose its relevance to design practice. In the end they proposed that maintaining accountability will help to resolve complications that arise from dealing with theory, methods and art.

Sometimes a part may be very complex such that regular manufacturing process may be time consuming and hence expensive. In order to enhance and ensure manufacturability of such part, it may be necessary to develop a work-holding device (Fixture) that will provide an easier way of manufacturing the part.

Fixtures are work-holding devices that are used in manufacturing operations such as machining, assembly, inspection, and feeding, (Subramanian et al. (2001). For a given part, the fixture is unique if there is only one possible design for the part and not unique if there are numerous designs possible for such a part. This characteristic is dependent on the complexity of the part. When a part has been designed to minimize all these complexities, the ability to incorporate manufacturability through fixture, and the design of the fixture will depend on the designer's expertise and experience.

Intuitively, performance evaluation of a fixture design solution is very difficult because of the highly non-linear relationship of the design parameters. For a given part, it is not immediately apparent if a fixture design solution is optimal or near optimal. Therefore, it is critically important for designers who wish to harness their drive for success to understand product development and the application of product development tools and methods.

The concurrent design is achieved in part by specifying single tolerance for both the part and the fixture. Product design has a profound effect on the part setup thereby delaying availability of the part, a design for zero setup beyond the initial setup approach is employed. The approach specifies a suitable datum in each plain from which all dimensions are referenced.

In moving from Computer Aided Design (CAD) to Computer Aided Manufacturing (CAM), the CAD/CAM systems need technical information at the different stages of the manufacture before machining for the definition of the tool trajectories and during the machining for an efficient process monitoring, Cherif et al. (2003). All available CAM software today are able to generate toolpaths for a part based on the CAD model, the rough part model, and the dimension of the cutting tool. The part is created with respect to the part accuracy and the theoretical surface finish. Since CAM software has no knowledge of the manufacturing systems, only some of the geometrical aspects of the cutting process are taken into consideration.

This paper describes a very simple method of manufacturing parts on a 3-axis CNC machining center without the burden of extra investment on modern attachment. The approach simplifies a given 3-D design model that was designed for manufacture on multi-axis machine by inverting it as a 2-D model. It defines machining parameters and setup methods that will enhance the manufacturability of the part on 3-axis CNC machine. The approach explores a design innovation continuum, which can be described as a creative process whose outcomes enable a designer to increase innovativeness by using the full spectrum of design. Na, Choi and Harrison (2017) earlier explored the technique where they focused on applying the concept to manufacturing and business processes. Rather than using case studies of manufacturing companies, as did Na et.al, this idea used intuitive knowledge and improvisation.

#### Parts Manufacturability

Design for manufacturability involves application of part forming models, which can be basic rules, analytic formulas or complex finite element process simulations. A common failure in part design is designing parts that look good and are considered to serve its desired purpose but are very difficult to manufacture. This difficulty in manufacture makes the part expensive because it is hard to setup and hence takes more time to manufacture. The part may also turn out to be unreliable due to the difficulty in maintaining the extra care required to achieve the required geometry.

#### Approach

The process follows a work breakdown structure (WBS), which enhances hierarchical arrangement and construction that provides clear and logical grouping of the design components as shown in Figure 1. WBS has successfully been used to solve project problems by: 1) proactively and logically plan out the project to completion, 2) collecting the information about work that needs to be done for a project, and 3) organizing activities into manageable components that will achieve project objectives (Dym and Little 2009). The integrated design approach proposed considers the concurrent design of the part with the following integrated approach Figure1 explored.

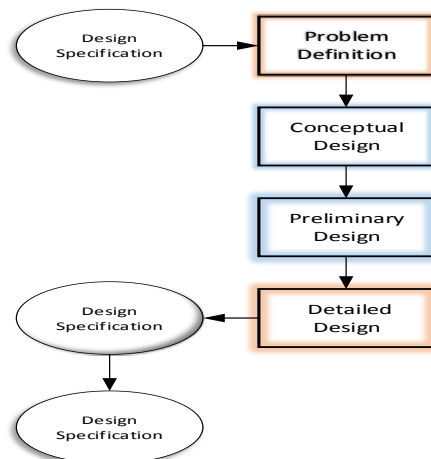

**Figure 1: Integrated Design Approach**

The process follows a work breakdown structure (WBS), which enhances hierarchical arrangement and construction that provides clear and logical grouping of the design components as shown in Figure 2.

#### Integrated Phases Description

The problem definition phase expresses the design requirements, dimensions, tolerances or allowances, surface finishing, etc. Conceptual design explores the different concepts that can be used to achieve the objectives. At this phase, techniques of achieving the objective is identified and set to reflect the special and structural relationship of the part and the fixture. Prior to the detailed design phase, the preliminary design serves as a testbed to be used to develop the detailed design which, looks at designing the part and the fixture at different levels in a 3-D that are integrated at the final design phase.

To better explain the approach used, the bracket in Figure 2a will be used. It could be said that the easiest and most economical way to machine the bracket (Figure 2a) is using a multi-axis CNC machining center. It is evident that using a conventional machining process will require more machines, setups, tools, and therefore more time. However, where a multi-axis machining center is not available, the same part can be machined on a 3-axis machining center by the method hereby described at no expense to time, quality, efficiency, and performance. The process of machining this on a 3-axis CNC machine begins with an initial design shown in Figure 2b.

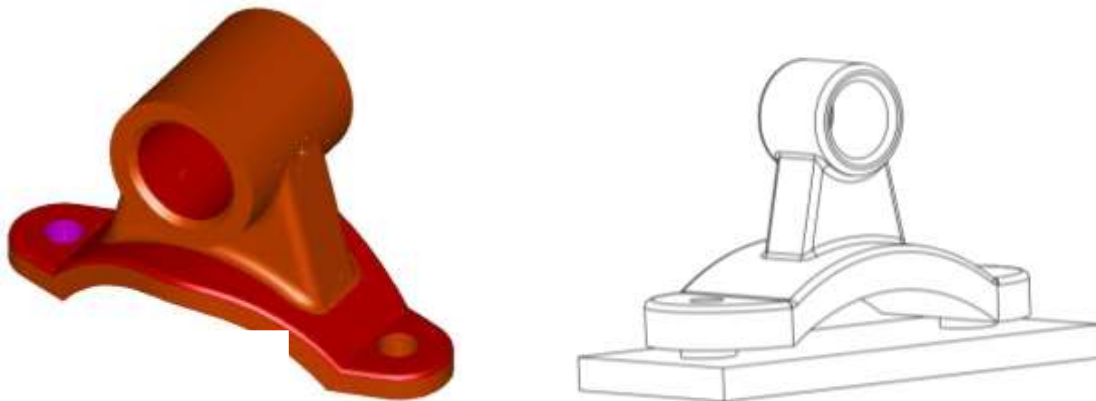

**Figure 2:** A 3-D detailed redesign of part

In design for manufacture, one can make a plastic part easier to injection mold by changing its drafting angle formed by the difference in wall thickness from the part at the inside of a mold compared with the wall thickness at the end of the mold. Using the analogy, to enhance manufacturability of the part on a 3-axis machining center, one can do one of two things: 1) transform the drawing from its current 3-D to a 2-D or 2) create an inverted format of the present 3-D. A fixture can then be designed to manufacture the part in either its 2-D or inverted state.

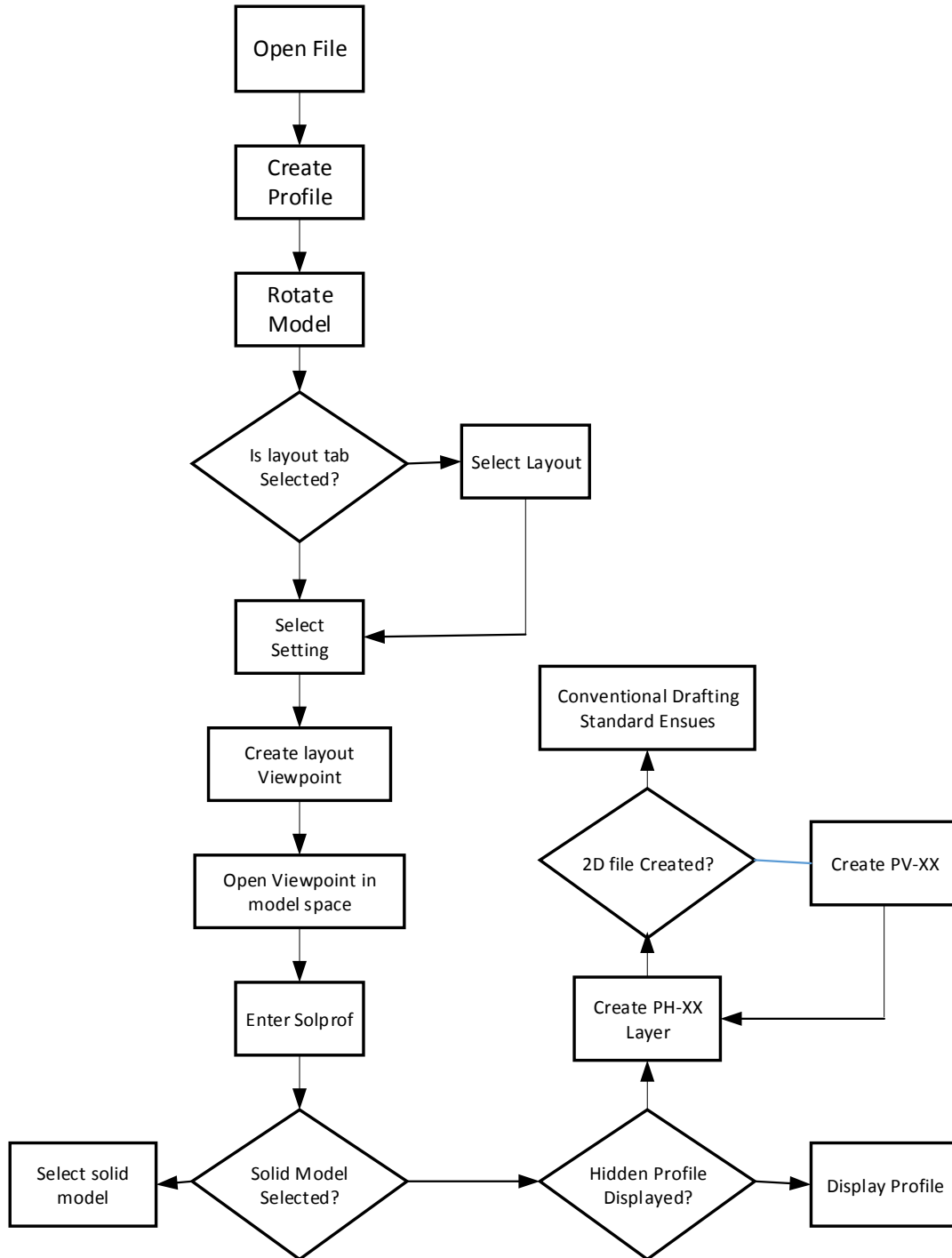
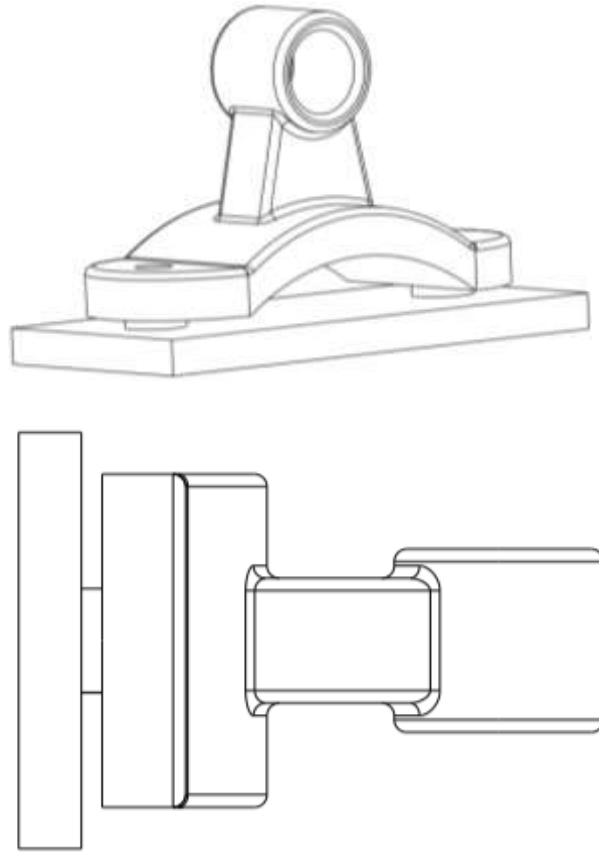

Figure 3: 3-D to 2-D flowchart

In converting from 3-D to 2-D, it was discovered that all Z-axis information was lost because the drawing is now developed on level zero (0). This has affected the generation of the machining code by the CAM software. It was decided at this point to use the inverted model (Figure 4) that retains all the Z-axis information and therefore makes the code easier to generate for the machine.



**Figure 4:** Inverted integration design

Some important characteristics of a fixture are a) ability to accommodate parts accurately in the same position and b) ability to maintain its location precisely with sufficient clamping force during the manufacturing operation. A fixture can be designed to accommodate family of parts or to accommodate one unique but complex part. In order to manufacture the bracket thus presented in this example, the fixture in Figure 3 is designed to accommodate and hold the workpiece. The fixture rather than the workpiece is used to set all work and machine coordinates. It remains fixed on the machine while the part is being manipulated as desired throughout the entire manufacturing process.

On the CNC machine, three reference points must be understood before attempting to manufacture a part. These are the machine origin, part origin and program origin. The machine origin is set by the manufacturer; the part origin is the origin of the absolute coordinate system while the program origin is the distance from the tool tip to the work origin. The part origin can be set at any point inside the machine's electronics grid system limits. On the machining center, the part origin can be established at any convenient point on the part or even out of the part in the physical and electronics limits of the machine. However, it must be clear that the location of this point determines the efficiency of the program as it establishes the tool starting point. The efficiency or improvement was determined by considering the total codes for the old and new methods. Thus the productivity improvement is:

Where,

- $\xi$  = the efficiency of the process
- N = the total number of manufacturing processing blocks in the original design
- P = the total number of manufacturing blocks in the new/proposed design

Three methods were first tested using CAM simulation system and then tested practically. With our example (the bracket), the setup and the machining process are both shown in Figure 4. The upper left lower corner of the fixture is chosen to enhance consistency when reversed to manufacturing other end of the bracket. Initially, the part goes in as a solid block and machined to the shape shown in Figure 4. The toolpath in Figure 5 shows all surfaces that were machined in one setting. A process that would have been difficult without the inverted design. After this section is completed, the part is rotated in the fixture to machine the other end as

shown in Figure 4. The time required to rotate the part is almost negligible due to the use of the fixture rather than the part as the part origin.

## II. CONCLUSION.

Ironically, it was purported earlier in this paper that multi-axis machining center will be an ideal solution for the manufacture of a complex part. However, it has been proved in this study that this is not always true. The bracket chosen as an example in this study is considered relatively simple because of its symmetry. When the process of manufacturing the part using the multi-axis is compared to the method described in this paper, it was found that the time to manufacture the part with the described method is 6.94% worse than the time for multi-axis method without a fixture. Also, the machining code generated for the described method was 624 blocks less than the same code using the multi-axis method. However, when compared to the 3-axis machining the improvement was 22.34%. This improvement came as a result of the drastic reduction in the setup time. In the integrated design, the part was first setup as shown in Figure 4, when the top was completed, the fixture was left clamped and the part merely flipped without any additional setup time on the machine.

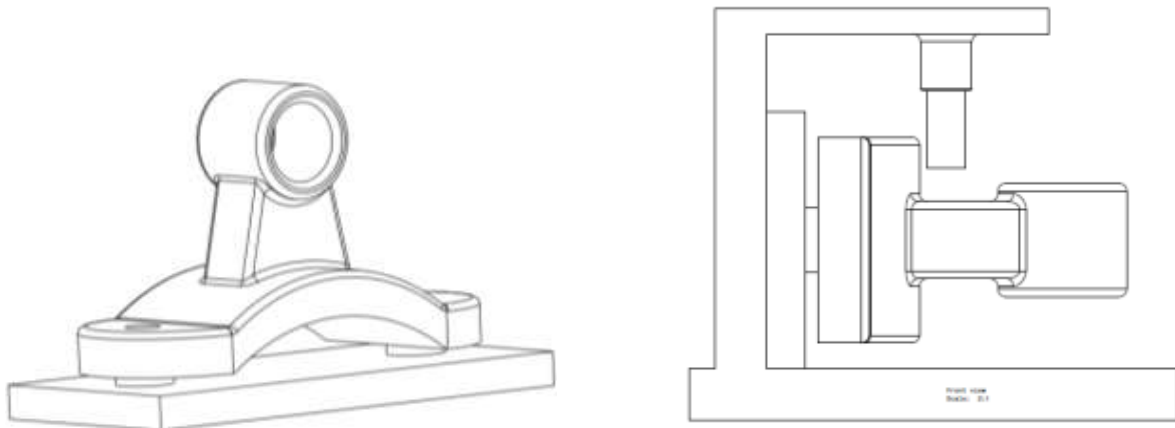

**Figure 4:** Setup and manufacturing process

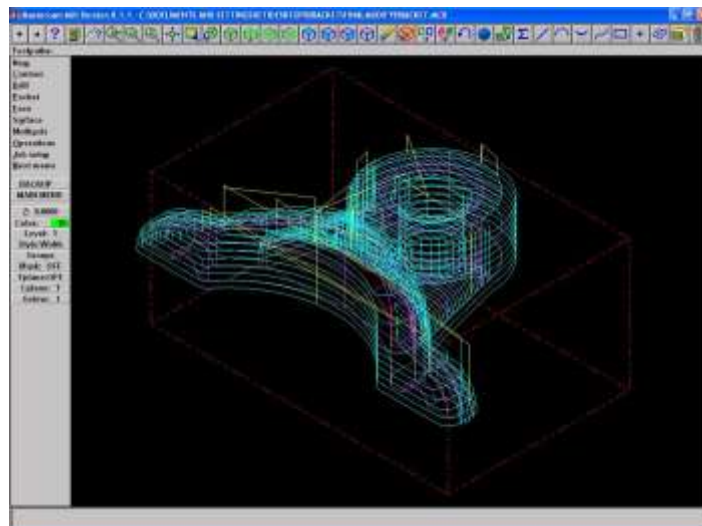

**Figure 5:** Machining Toolpath

The design and setup allows the entire surface, sides, and the hole to be machined at the same time while the opposite surface is machined just by turning over the fixture without any further setup action on the part.

A time study of both process was conducted to ascertain improvement. Without the proposed approach, the amount of human involvement increases the completion time more drastically than with the integrated approach.

**Table 1:** Comparison of different aspects the current and the proposed.

| Factor                 | Current | Proposed | Efficiency (%) |
|------------------------|---------|----------|----------------|
| Codes                  | 1, 826  | 1202     | 22.34          |
| Setup steps (Minutes)  | 2       | 2        | 0              |
| Setup time (Minutes)   | 13.25   | 8.17     | 38.34          |
| Cutting time (Minutes) |         |          |                |

### REFERENCES

- [1]. Kazuya G. KOBAYASHI\*, Daisuke FUJISHIRO2, Ken YAMAGUCHI3, and Katsutoshi; (2013) 3D Shape Modification Based on Gesture Input (International Journal of CAD/CAM Vol. 13(2), pp. 109-114 (2013)
- [2]. Clive Dym and Patrick Little (2009) "Engineering Design: A project based Introduction"; 3/e John Wiley.
- [3]. Maaikle Kleinsmann, Rianne Valkenburg, and Janine Sluijs (2017), Capturing the value of design thinking in different innovation practices. International Journal of design, 11(2) pp 25-40
- [4]. Mieke Van der Bijl-Brouwer and Mascha van der Voort (2013) Understanding Design for Dynamic and Diverse Use Situations. International Journal of Design, 8(2) pp 29 – 42.
- [5]. Wentao Fu & Matthew I. Campbell (2015); Concurrent fixture design for automated manufacturing process planning. International Journal of Advanced Manufacturing Technology (2015) 76:375–389 DOI 10.1007/s00170-014-6247-z
- [6]. Jea Hoo Na, Youngok Choi, and David Harrison (2016), The Design innovation Spectrum: An Overview of Design Influences on Innovation for Manufacturing Companies. International Journal of Design, 11(20), pp 13-24.
- [7]. Naoya Tsuruta, Jun Mitani, Yoshihiro Kanamori, and Yukio Fukui (2013), Interactive Design of 3D Geometry Made by Bending Inextensible Sheet Material Containing Slits. International Journal of CAD/CAM 13(2) pp 23 – 29.
- [8]. Yinze Hu · EL-Sayed S. Aziz (2016), **Creativity-based design innovation environment in support of robust product development**. International Journal on Interactive Design and Manufacturing, 10(4) pp 335 – 353.
- [9]. **Rajit Ranjan, Rutuja Samant, and Sam Anand (2017), Integration of Design for Manufacturing Methods With Topology Optimization in Additive Manufacturing. Journal of Manufacturing Science and Engineering, Vol 139 pp1-13.**
- [10]. Ilpo Koskinen1 and Peter Gall Krogh (2015) Design Accountability: When Design Research Entangles Theory and Practice. International Journal of Design 9(1), pp 121 – 127.
- [11]. Yoori Koo (2016), The role of Designers in Integrating Societal Value in the Product and Service Development Processes. International Journal of Design, 10(2) pp 49 – 65.
- [12]. V. Venkataramana, Yadavalli Basavaraj, and Banakar a Nagaraj (2013). Concurrent Engineering: An Effective Engineering Management Strategy. International Journal of Production Technology and Management. 4(1), pp 11 – 16.
- [13]. Ilpo Koskinen and Peter Gall Krogh (2014), Design Accountability: When Design Research Entangles Theory and Practice. International Journal of Design 9(1) 2015, pp 121 – 127.

Molu O. Olumolade" Manufacturability through Integrated and Design Innovation Continuum" Research Inventy: International Journal of Engineering And Science, vol. 09, no. 01, 2019, pp. 24-31