

Automobile Gearbox Holding Device during Maintenance

¹. Adzimah, Stephen Kwasi ². Akinwonmi, Ademola Samuel ³. Oswell, Paintsil
^{1, 2, 3}. Department Of Mechanical Engineering University Of Mines and Technology, Tarkwa, Ghana

Abstract - The method used by the technical teams during repairs on gearboxes of automobile always poses danger, the faulty gearbox, at a stage, has to be removed and some components restored or completely replaced. This technique has always been causing fatigue and much risk of worker injury; endangering the lives of mechanics. This paper presents the design of an efficient, reliable, ergonomic, safe and cost-effective device to hold the automobile gearbox in position during its maintenance. The main components of the design include gearbox, support plate, power screw, link and spur gears. The mechanism in the design causes the reciprocating movement of the support plate when the power screw connecting the two brackets performs rotational motion. The base in the form of a board with wheels makes easy the drawing and pushing of the device with the gearbox on it. Mild steel was used as the material. The efficiency of the device is good enough to be used for the purpose for which it is designed. The device will save time, minimize and eliminate wasted efforts, risks and dangers involved in holding gearboxes of automobile during maintenance workshops.

Keywords: automobile, design, device, gearboxes, mechanism

1. INTRODUCTION

One of the greatest inventions of engineering, automobile has all the time undergone servicing and maintenance. It is useful and does a lot of work. However, sometimes, because of the improper way it is handled, and also, due to accidents, it develops faults and this results to its breakdown. Most automobile breakdowns are caused mainly by problems with the engine, gearbox or suspension. The application of stress to any material will lead to the production of elastic and/or plastic strain and if the stress is increased progressively, fracture will ultimately occur Raymond, (1990). The safe operation of a vehicle support is dependent on its condition in use, and deterioration would lead to a significant risk to the operator or other worker Provision and Use of Work Equipment Regulations, (1998).

In Ghana, there are numerous automobile maintenance shops. However, maintenance engineers in these shops use dangerous means to take out gearboxes for repair when automobile breakdown is a result of transmission failure. About six men are involved during the process of either separating the gearbox from the flywheel and the clutch for repair, or restoring it to its position after repair, or replacement of the gearbox. About four of these men lie on their backs beneath the automobile with hands laid on the gearbox to support while the other two in the cab hold ropes wrapped round the gearbox to ease the pressure of the gearbox on those beneath the car. In olden times, thousand of slaves had to be arranged whenever a heavy load had to be lifted or dragged Khurmi, (2009). This method used by the automobile maintenance shops is inconvenient and can result in severe injuries.

In order to avoid breakdown, vehicles must be serviced and maintained at regular intervals and, in the event of a breakdown, action must be taken to clear the road and repair the vehicle so as to restore it to good working condition, as quickly as possible. In most countries it is the motor vehicle repair and maintenance industry that performs the bulk of vehicle maintenance and repair work. Many parts producing and mechanical devices manufacturing companies as well as individual engineers have tried many useful attempts to solve this gearbox removing problems. Sometimes the automobile or vehicle is lifted a little high above ground level with different types of lifting devices in order to perform maintenance work on components beneath the body of the car but when the gearbox has to be replaced or removed from its position a special device will be required to perform such a function. Some of these attempts have resulted in the invention of special devices such as the jib and the hydraulic transmission jack as shown in figure 1 and figure 2. Some designs of the transmission jack are operated by foot and others with the hand. Most of these jacks are bulky, very expensive and too high to be used under vehicles that are not jacked up too much. The objective of this work is to design a device that is reliable ergonomic efficient cost effective and safe in order to minimize and eliminate the risks involved during gear box maintenance

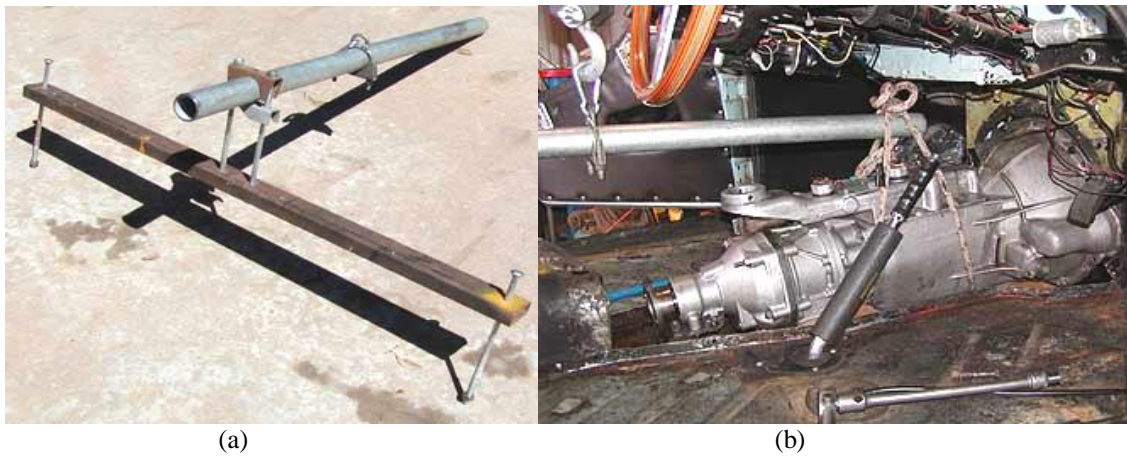

Fig. 1 Jib Lifting Device in operation



Fig. 2 Hydraulic Transmission Jack

II. MATERIALS AND METHODS

2.1 Description of the Proposed Design

The proposed design is made up of several separate components put together to form a linked mechanism. It has a support plate on which the gearbox will rest. There are also the links, joined together by pins to the brackets and the joints as shown in figure 3 and figure 4. This mechanism makes the up and down movement of the support plate possible when the power screw connecting the two brackets is turned either clockwise or counterclockwise. The device also has a base in the form of a board with wheels to make easy the drawing and pushing of the device with the gearbox on it. A motor is used to turn the power screw by means of a gear.

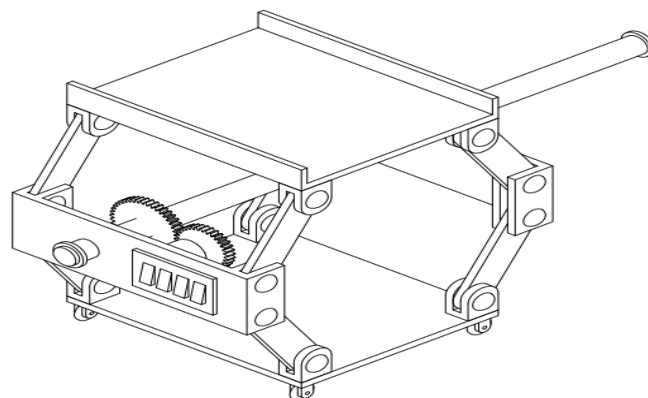

Fig. 3 Proposed Design

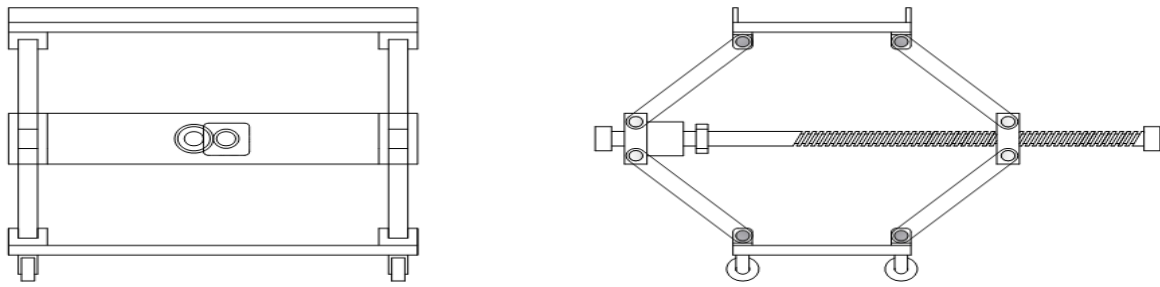

Fig.4 Front and End View of the Design

2.2 Principle of Operation of the Proposed Design

This design operates on the same principle on which a bolt and a nut operates in that when a bolt rotates in a nut, it changes rotational angular motion to linear motion to transmit power or to develop large forces. In this design, only one of the two brackets has its hole threaded. The other one has a smoothed hole. The portion of the power screw that is through this hole is also smoothed to facilitate its rotational movement in the hole. During operation, the operator presses the start button to start the motor which has a gear that is in mesh with another gear mounted on the power screw.

2.3 Selection of the Materials for the Components of the Proposed Design

AISI 1025 steel with density 7.858 g/cm^3 , modulus of elasticity E 207 GPa, Poisson's ratio 0.30, yield strength 370 MPa and a tensile strength of 440 MPa is selected for all the components Callister and Rethwisch, (2010) except the motor and the pins.

2.4 Design Calculations of the Main Components

In order to reduce material cost and component over design, a factor of safety 2 would be used for the proposed design. ($n = 2$).

The device is designed to support a maximum weight of 450 lbs. (2001.6 N.) When the jack is in the top position the distance between the center lines of nuts is 400 mm and in the bottom this distance is 1000 mm. The eight links of the device are symmetrical and 350 mm long each. The link pins in the base are set 400 mm apart.

2.5 Design of Gearbox Support Plate

The support plate with the load distribution is shown in figure 5.

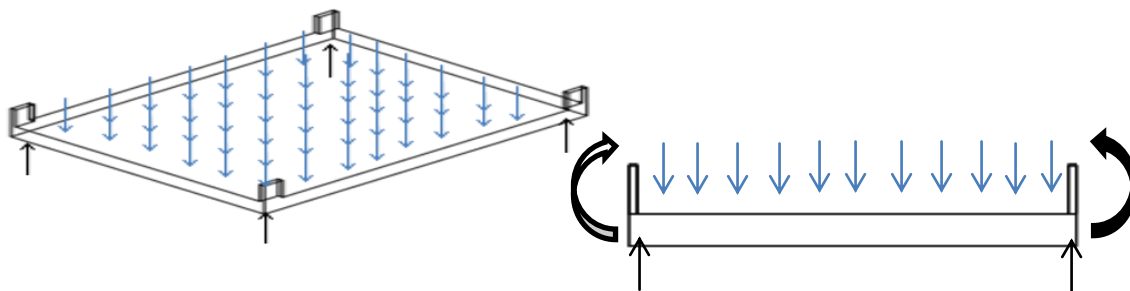

Fig. 5 Support Plate with Load Distribution

Weight of gearbox, $W_G = 2001.6 \text{ N}$

Reactions at the supports, R

$$\sum R = W_G$$

$$4R = 2001.6 \text{ N}$$

$$R = \frac{2001.6}{4} = 500.4 \text{ N}$$

Assuming the Gearbox Support Plate to be a beam subjected to bending and shear stress, then applying the maximum shear stress theory;

$$\tau_{max} = \frac{\sigma_y}{2 \times n} = \frac{1}{2} \left[\sqrt{(\sigma_{bending})^2 + 4\tau_{shear}^2} \right] \dots \dots \dots (1)$$

σ_y = yield strength of the material

Also; maximum bending moment, $\sigma_{bending} = \frac{M_{max} c}{I} \dots \dots \dots (2)$

maximum shear stress, $\tau_{shear} = \frac{3V}{2A} \dots \dots \dots (3)$

S. F (V) = 1000.8 – 5004(X) N

B.M (M) = 1000.8(X) - 5004 $\frac{X^2}{2}$ Nm.

$M_{max} = 100.08$ N/m and $V = 1000.8$ N

Substituting these values into equations 2 and 3

$$\tau_{shear} = \frac{3 \times 1000.8}{2 \times 0.55h} = \frac{3002.4}{1.1h}$$

$$I = \frac{0.55 \times h^3}{12}$$

$$\sigma_{bending} = \frac{100.08 \times \frac{h}{2}}{\frac{0.55 \times h^3}{12}} = \frac{50.04h}{0.046h^3} = \frac{50.04}{0.046h^2}$$

Cross sectional area, A = 0.55h

and $c = \frac{h}{2}$

$$\frac{370 \times 10^6}{2} = \left[\sqrt{\left(\frac{50.04}{0.046h^2}\right)^2 + 4\left(\frac{3002.4}{1.1h}\right)^2} \right]$$

$h = 2.425 \times 10^{-3} \text{m} = 0.00242 \text{m}$

$h = 2.425 \text{mm}$

2.6 Design of Power Screw

The Power Screw is shown in figure 6. A little consideration shows that the maximum load on the square threaded screw occurs when the jack is in the bottom position.

Let θ be the angle of inclination of the link with the horizontal.

From geometry, we find that

$$\cos\theta = \frac{0.3}{0.35} = 0.8571 \text{ or } \theta = 31^\circ$$

Each joint carries half the total load on the jack and due to this, the link is subjected to tension while the square threaded screw is under pull. The magnitude of the pull on the square threaded screw becomes;

$$F = \frac{W_c}{2 \times \tan\theta} \dots \dots \dots (4)$$

$$\frac{2001.6}{2 \times \tan 31} = 1665.61 \text{ N}$$

Since a similar pull acts on the other joint, therefore total tensile pull on the square threaded rod,

$$W_1 = 2F = 2 \times 1665.61 = 3331.22 \text{ N}$$

Let d_c = core diameter of the screw

We know that load on the screw, (W_1)

$$3331.22 = \frac{\pi}{4} (d_c)^2 \sigma_t = \frac{\pi}{4} (d_c)^2 \times 440 \times 10^6 = 345.6 \times 10^6 (d_c)^2$$

$d_c = 3.10 \times 10^{-3} \text{m} = 3.1 \text{mm}$

Since the screw is also subjected to torsional shear stress, therefore to account for this, let us adopt

$$d_c = 40 \text{ mm}$$

∴ Using a pitch of 6 mm, normal or outer diameter of the screw,

$$d_o = d_c + p = 40 + 6 = 46 \text{ mm}$$

$$\text{and mean diameter of the screw, } d = d_o - \frac{p}{2} = 46 - \frac{6}{2} = 43 \text{ mm}$$

$$\text{Checking for principal stresses, } \tan \alpha = \frac{p}{\pi d} = \frac{6}{\pi \times 43} = 0.0444 \quad (\alpha \text{ is the helix angle})$$

and the effort required to rotate the screw,

$$P = w_1 \left(\frac{\tan \alpha + \tan \phi}{1 - \tan \alpha \tan \phi} \right) \dots \dots \dots (5)$$

Khurmi and Gupta, (2005)

Using a coefficient of friction, $\mu = \tan \phi = 0.2$

$$P = 3331.22 \left(\frac{0.0444 + 0.2}{1 - 0.0444 \times 0.2} \right) = 821.4446 \text{ N}$$

$$\therefore \text{Torque required rotating the screw, } T = P \times \frac{d}{2} = 821.4446 \times \frac{0.043}{2} = 17.6611 \text{ Nm}$$

$$\text{and shear stress in the screw due to torque, } \tau = \frac{16T}{\pi(d_c)^3} \dots \dots \dots (6)$$

$$= \frac{16 \times 17.6611}{\pi(0.04)^3} = 1.4054 \text{ MPa}$$

Also, direct tensile stress in the screw,

$$\sigma_t = \frac{W_1}{\frac{\pi}{4}(d_c)^2} \dots \dots \dots (7)$$

$$= \frac{3331.22}{\frac{\pi}{4}(0.04)^2} = 2.6509 \text{ MPa}$$

Maximum principal (tensile) stress,

$$\sigma_{t(\max)} = \frac{\sigma_t}{2} + \frac{1}{2} \sqrt{(\sigma_t)^2 + 4(\tau)^2} \dots \dots \dots (8)$$

Khurmi, (2005)

$$\sigma_{t(\max)} = \frac{2.6509 \times 10^6}{2} + \frac{1}{2} \sqrt{(2.6509 \times 10^6)^2 + 4(1.4054 \times 10^6)^2} = 3.2573 \text{ MPa}$$

and maximum shear stress,

$$\tau_{\max} = \frac{1}{2} \sqrt{(2.6509 \times 10^6)^2 + 4(1.4054 \times 10^6)^2} = 1.9318 \text{ MPa}$$

Since the maximum stresses are within safe limits, therefore the design of the square threaded screw is satisfactory.



Fig. 6 Power Screw

2.7 Design of Link

Due to the load, the links may buckle in two planes at right angles to each other. For buckling in the vertical plane (i.e. in the plane of the links), the links are considered as hinged at both ends and for buckling in a plane perpendicular to the vertical plane, it is considered as fixed at both ends Khurmi and Gupta, (2005).

$$\text{The maximum load on a link} = 500.4 / \sin 31 = 971.58 \text{ N}$$

The links must be designed for a buckling load,

$$W_{cr} = \frac{\sigma_{all} \times A}{1 + a \left(\frac{L}{k} \right)^2} \dots \dots \dots (9)$$

Khurmi and Gupta, (2005)

$$\text{Buckling load on the link, } W_{cr} = 971.58 \times 2 = 1943.16 \text{ N}$$

Let t_1 = thickness of the link, and

b_1 = Width of the link

Assuming the width of the link is two times the thickness of the link, i.e. $b_1 = 2t_1$, then the cross-sectional area of the link,

$$A = t_1 \times 2t_1 = 2(t_1)^2$$

And

moment of inertia of the cross-section of the link,

$$I = \frac{1}{12} \times t_1 \times (b_1)^3 = 0.67(t_1)^4$$

Radius of gyration,

$$k = \sqrt{\frac{I}{A}} = \sqrt{\frac{0.67(t_1)^4}{2(t_1)^2}} = 0.335(t_1)^2 \dots\dots\dots(10)$$

For buckling of the link in the vertical plane, the ends are considered as hinged Khurmi, (2005), therefore equivalent length of the link, $L = l$ (length of link) = 0.35 m

And Rankine's constant, $\alpha = \frac{\sigma_y}{\pi^2 \times E} = \frac{370 \times 10^6}{\pi^2 \times 207 \times 10^9} = 0.0001811$

According to Rankine's formula, buckling load (W_{cr}),

$$1943.16 = \frac{\sigma_{all} \times A}{1 + \alpha \left(\frac{L}{k}\right)^2} = \frac{185 \times 10^6 \times 2(t_1)^2}{1 + 0.0001811 \left(\frac{0.35}{0.335(t_1)^2}\right)^2} t_1 = 0.0318 \text{ m} = 31.8 \text{ mm}$$

$$b_1 = 2 \times 31.8 = 63.3 \text{ mm}$$

Now considering the buckling of the link in a plane perpendicular to the vertical plane moment of inertia of the cross-section of the link, $I = \frac{1}{12} \times b_1 \times (t_1)^3 = 0.167(t_1)^4$

$$k = \sqrt{\frac{I}{A}} = \sqrt{\frac{0.167(t_1)^4}{2(t_1)^2}} = 0.0835(t_1)^2$$

For buckling of the link in a plane perpendicular to the vertical plane, the ends are considered as fixed, therefore Equivalent length of the link,

$$L = l/2 = 0.175 \text{ m}$$

Then,

$$W_{cr} = \frac{\sigma_{all} \times A}{1 + \alpha \left(\frac{L}{k}\right)^2} = \frac{185 \times 10^6 \times 2(t_1)^2}{1 + 0.0001811 \left(\frac{0.175}{0.0835(t_1)^2}\right)^2}$$

Substituting the value of $t_1 = 0.0318 \text{ m}$, gives

$$W_{cr} = 480.38 \text{ N}$$

Since this buckling load is less than the calculated value (i.e. 1943.16 N), therefore the link is safe for buckling in the vertical plane.

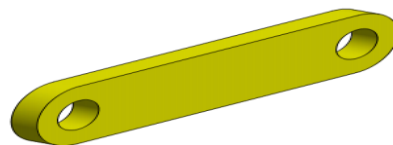

Fig. 7 Link

2.8 Gear Specification

The gear on the power screw is preferred to rotate at a speed of 16 rpm (N_2). A module of 1.25 for the spur gears is needed (Budynas and Nisbett, 2008). The Spur gears should be cut at a pressure angle of 20° and a motor of rated speed 60 rpm(N_1)

$$\begin{aligned} \text{Train value of the gears} &= \frac{\text{speed of driven gear, } N_2}{\text{speed of driver gear, } N_1} \\ &= \frac{16}{60} \end{aligned}$$

Because the pitch diameter of the screw's gear must exceed the normal diameter of the power screw, and also not too much than this value to reduce the torque on the gear, a pitch diameter of 51 mm is considered appropriate for this design.

Then,

$$\begin{aligned} \text{number of teeth on this gear} &= \frac{\text{pitch diameter, } d}{\text{module, } m} \\ &= \frac{51}{1.25} = 40.8 \approx 41 \text{ teeth} \end{aligned}$$

Also,

$$\frac{N_2}{N_1} = \frac{d_1}{d_2}$$

The pitch diameter of the motor's gear, $d_1 = \frac{16}{60} \times 51 = 13.6 \text{ mm}$, therefore,

$$\text{number of teeth on the motor gear} = \frac{13.6}{1.25} = 10.88 \approx 11 \text{ teeth}$$

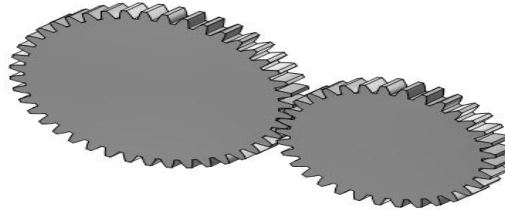

Fig. 8 Gear Mesh

2.9 Efficiency of the device, E

$$E = \frac{\text{mechanical advantage, } M.A}{\text{velocity ratio, } V.R} \times 100\% \dots\dots\dots(11)$$

$$\text{Where } M.A = \frac{\text{load}}{\text{effort}} = \frac{2001.6}{821.4446} = 2.4367$$

$$V.R = \frac{60}{16} = 3.75$$

$$E = \frac{2.4367}{3.75} \times 100\% = 64.9 \%$$

III. DISCUSSION OF RESULTS

A device which is efficient, reliable, ergonomic, safe and cost-effective device to hold the automobile gearbox in position during its maintenance has been designed. Figure 3 shows the proposed design while figure 4 shows the front view and side view. The Principle of operation of the design is easy and user friendly. The rotation of the power screw causes the bracket with the hole threaded to move axially back and forth on the screw enabling the links to oscillate and move the support plate up or down depending on the direction of rotation of the screw. The major components of the design (Gearbox support plate, power screw, links and base) are easy to fabricate and install.

IV CONCLUSION

This device will relieve stress and also prevent the possibilities of severe injuries on mechanics. The device is efficient enough to be used for the purpose for which it was designed based on the efficiency.

REFERENCES

- [1] Budynas, G. R. and Nisbett, K. J. (2011), Mechanical Engineering Design, McGraw-Hill Companies, Inc., New York, 9th edition, 1109 pp.
- [2] Callister, W. D. and Rethwisch, D. G. (2010), Materials Science And Engineering, an Introduction, John Wiley & Sons, Inc., 111 River Street, Hoboken, 8th edition, 88pp.
- [3] Karmot, (2011), Automobile Maintenance Accessories Handbook, 24th ed., Karmot Inc., Peoria, USA, pp. 4–97.
- [4] Khurmi, R.S. (2009) A Textbook on Engineering Mechanics S. Chand and Company Ltd, Ram Nager, New Delhi 20th Revised Edition, pg171. ISBN 8121926165.
- [5] Khurmi, R.S. and Gupta, J.K. (2005), Machine Design, Eurasia Publishing House (PVT.) Ltd, Ram Nagar, New Delhi, 1230 pp.
- [6] Provision and Use of Work Equipment Regulations 1998. Safe use of work equipment.. Approved Code of Practice and guidance L22 (Third edition) HSE Books ISBN 978 0 7176 6295 1
- [7] Raymond, A. Higgins (1990), Properties of Engineering Materials 4th Edition, Edward Arnold pp 348 ISBN 0340380349.